

# PARABODY

## *Serious Steel*

### 916101 ST DUMBBELL RACK

---

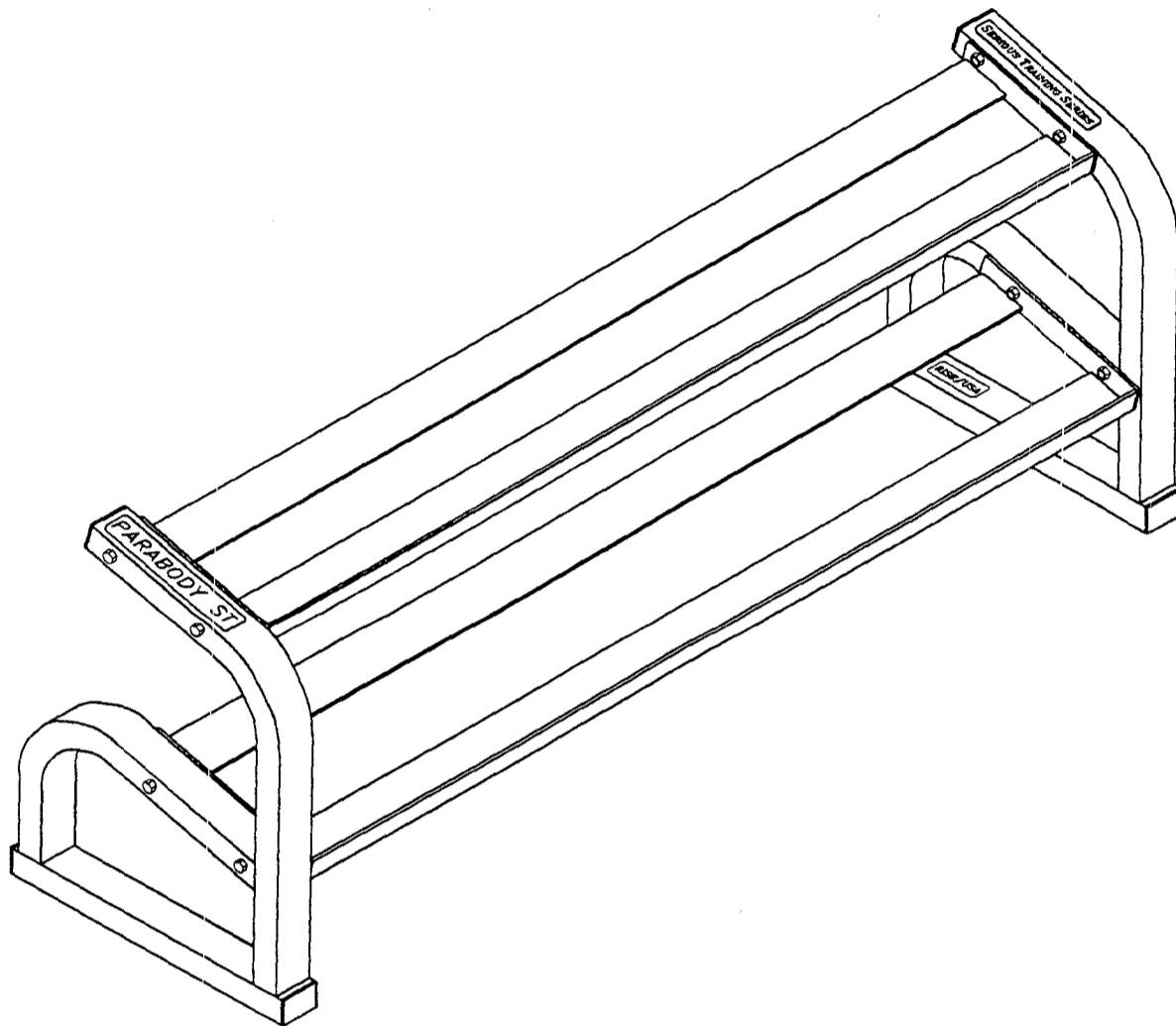

---

### ASSEMBLY INSTRUCTIONS

## IMPORTANT NOTES

There is a risk assumed by individuals who use this type of equipment. To minimize risk, please follow these rules:

1. Consult your physician before beginning any exercise program.
2. Inspect equipment daily. Tighten all loose connections and replace worn parts immediately. Failure to do so may result in serious injury.
3. Do not allow minors or children to play on or around this equipment.
4. Exercise with care to avoid injury.
5. If unsure of proper use of equipment, call your local Parabody distributor or call the Parabody customer service department at (800) 328-9714.

**Please note:**

- \* Thank you for purchasing the Parabody 916101 ST Dumbbell. Please read these instructions thoroughly and keep them for future reference. This product must be assembled on a flat, level surface to assure its proper function.
- \* We recommend cleaning your product (pads and frame) on a regular basis, using warm soapy water. Touch-up paint can be purchased from your Parabody customer service representative at (800) 328-9714.

## Tools Required for Assembly

- \* 3/4" wrench
- \* Ratchet with 3/4" socket
- \* Tape measure

## Bolt Length Ruler

**NOTE: BOLT LENGTH IS MEASURED FROM THE UNDERSIDE OF THE HEAD OF THE BOLT.**

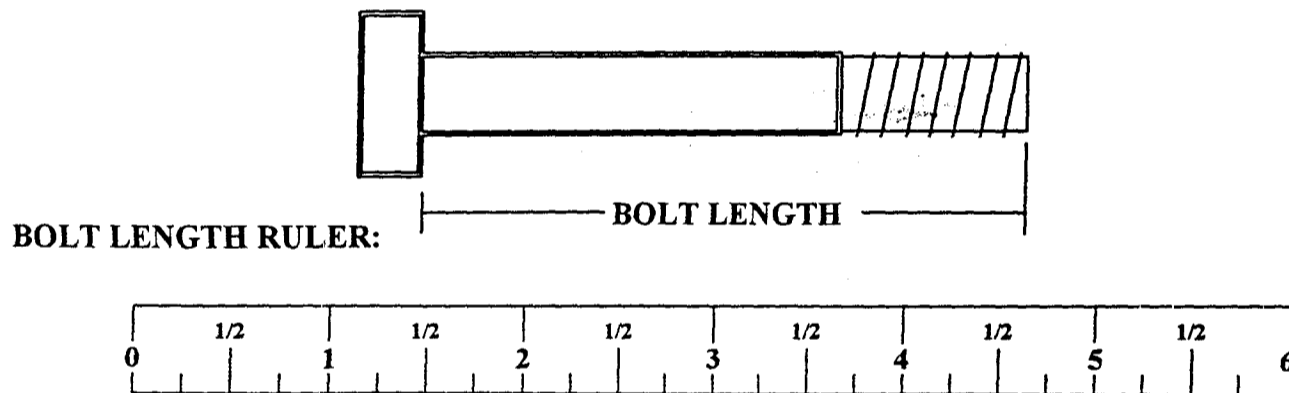

# PARTS LIST

KEY	PART #	DESCRIPTION	QTY
1	6688301	UPRIGHT FRAME	2
2	6688701	TOP TIER	1
3	6689001	BOTTOM TIER	1
4	3202103	1/2-13 X 4" BOLT	8
5	3102502	1/2" WASHER	8
6	3102801	1/2" LOCKNUT	8

**STEP 1:** Loosely attach **BOTTOM TIER (3)** between the **UPRIGHT FRAMES (1)** using four **1/2 X 4" BOLTS (4)** four **1/2" WASHERS (5)**, and four **1/2" LOCKNUTS (6)** as shown in figure 1.  
**(NOTE: BOTTOM TIER (3) is wider than TOP TIER (2)).**

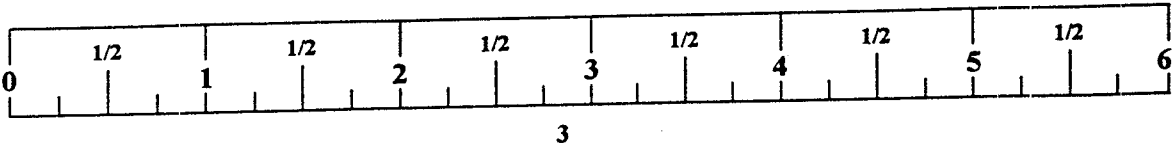
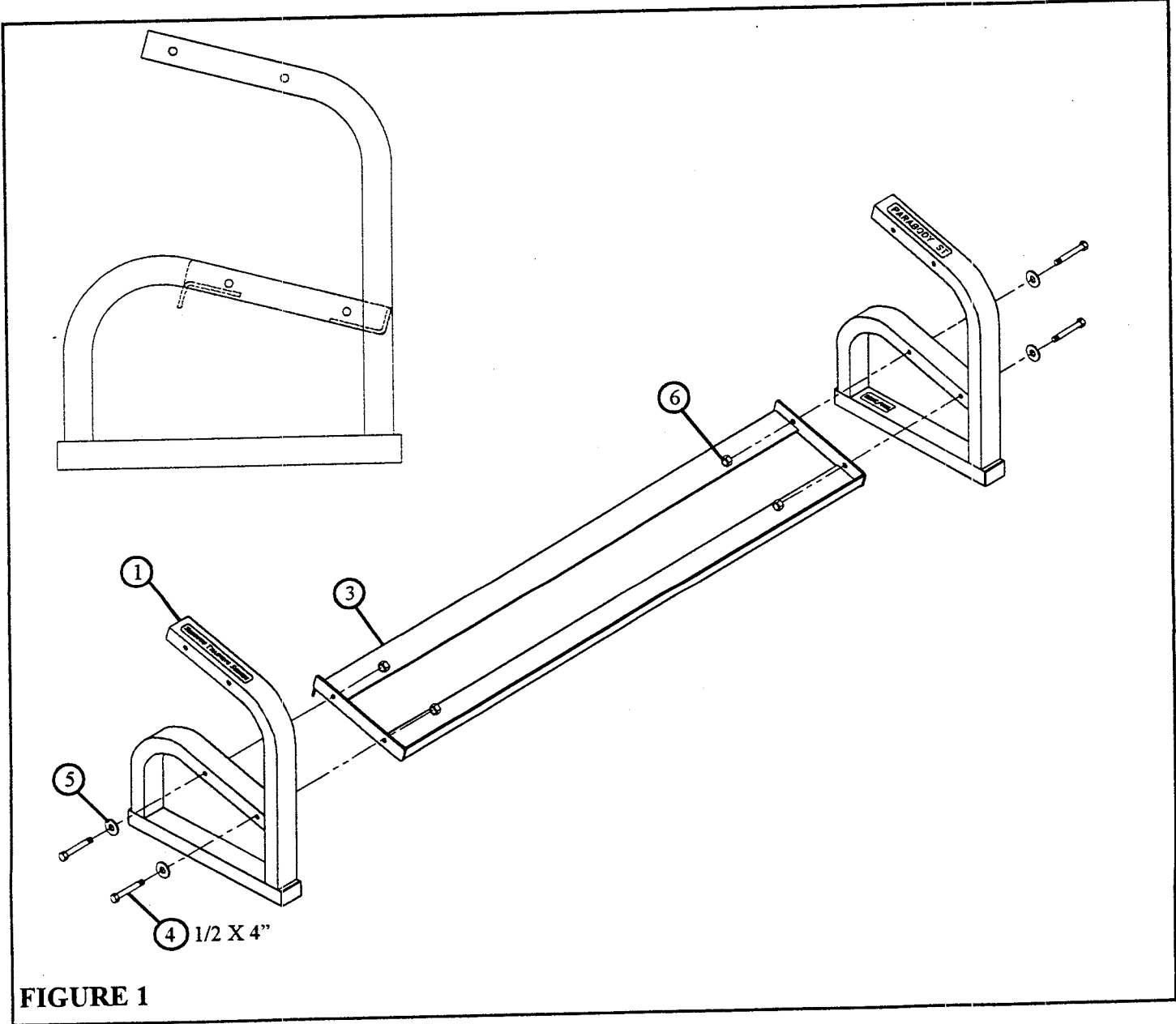

**STEP 2:** Loosely attach **TOP TIER (2)** between the **UPRIGHT FRAMES (1)** using four **1/2 X 4" BOLTS (4)**, four **1/2" WASHERS (5)**, and four **1/2" LOCKNUTS (6)** as shown in figure 2.  
**(NOTE: BOTTOM TIER (3) is wider than TOP TIER (2)).**

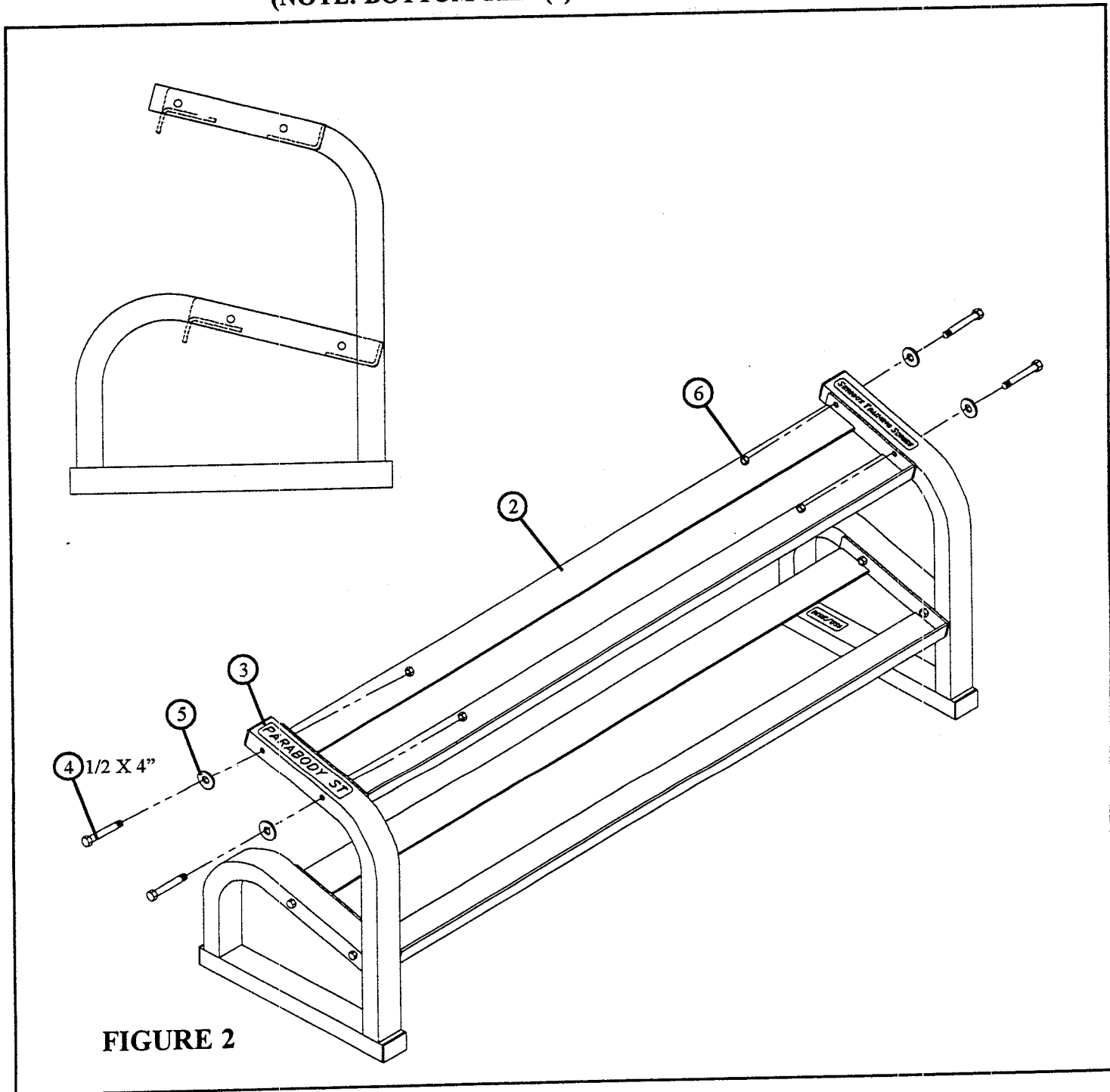

**STEP 3: SECURELY TIGHTEN ALL BOLT CONNECTIONS.**

